

UD2600LP

2008 MODEL YEAR



TRUCKS

Distributed by

Nissan Diesel America, Inc.

WHEELBASES

	H	K
GVWR (lb.)	25,995	25,995
Chassis Weight (lb.)	9,480	9,590
Front (lb.)	5,920	6,005
Rear (lb.)	3,560	3,585
Gross Payload (lb.)*	16,515	16,405
Wheelbase (in.) ** WB	177.17	192.91
Cab-to-Rear Axle (in.) CA	145.00	160.80
Rear Overhang (in.) RO	72.80	77.00
Overall Length (in.) OL	300.40	320.30
Typical Body Lengths (ft.)***	16/18	18/20
Turning Radius (ft.)	25.40	27.40

*Gross payload capacity equals GVWR minus chassis weight. Installation of specialized equipment or bodies may require frame reinforcement. **Wheelbase selection should be based on specific weight distribution. ***Typical body lengths assume water level load (no specific consideration for driver, passengers, or fuel) to maximize GVWR. Addition of ancillary equipment such as lift gates and refrigeration units not considered in calculations.

ENGINE

	MD230* - 24 Valve
	Turbo/Intercooled Diesel
	In-line 6 cylinder, Direct-injection
Horsepower	230 hp @ 2,500 rpm
Torque	506 lb. ft. @ 1,500 rpm
Displacement	469 in. ³ (7.684 L)
Cylinder Liner	Dry, replaceable
Air Compressor	14.1 CFM @ 2,600 engine rpm (nominal)
Fuel System	Electronically controlled common rail system
Air Cleaner	11 in., paper filter type (DONALDSON)
Cold Starting Aid	Automatic electric glow plug
Fan	Viscous type drive

*MD230 (J08E-TE) is a vendor engine manufactured for Nissan Diesel Motor Company.

FRONT AXLE

Rated Axle Capacity	9,480 lb.
Axle Type	"I" Beam
Suspension	Semi-elliptic leaf springs
Shock Absorbers	Telescopic type



*UD2600 shown here with dealer installed optional equipment.

TRANSMISSION

Ratios	STD	OPTION
	Nissan Diesel, MLS63B Manual, 6 forward speeds & 1 reverse synchromesh on 2nd through 6th gears	Allison, 2200RDS Automatic 5 forward speeds & 1 reverse
1st	6.72	3.51
2nd	4.03	1.90
3rd	2.30	1.44
4th	1.44	1.00
5th	1.00	0.74
6th	0.74	—
Rev.	6.12	5.09
R/A Ratio	4.88	4.88
Engine rpm @ 65 mph w/ 255/70R22.5	2,185	2,194

*Approximate engine rpm only. Allison will provide a performance scan by application on request.

CLUTCH

Hydraulic clutch with air assist
13.8 in. cerametallic friction material
Standard clutch wear indicator

STEERING

Integral power steering, gear driven pump
Steering Column Tilt & telescopic type

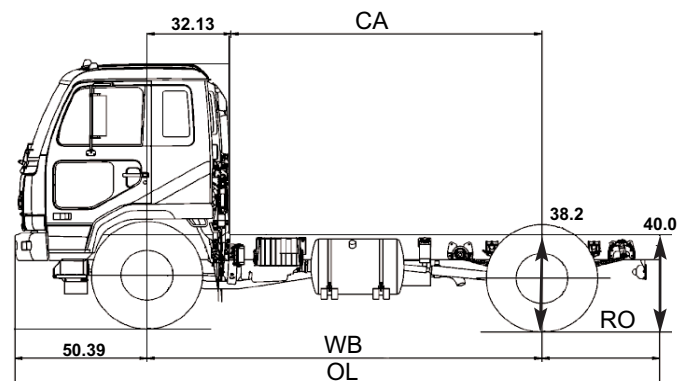
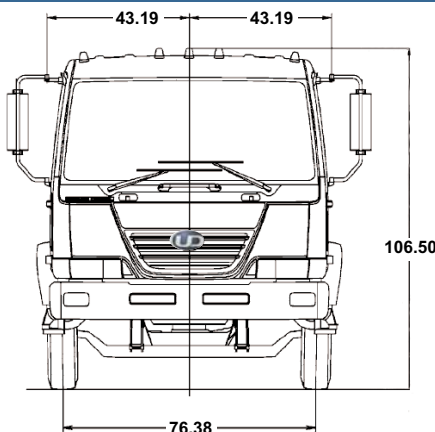

UD2600LP

2008 MODEL YEAR



TRUCKS

Distributed by
Nissan Diesel America, Inc.

REAR AXLE

Rated Axle Capacity 18,080 lb.
Axle Type Full-floating banjo housing
Suspension Semi-elliptic leaf springs with auxiliary springs

WHEELS & TIRES

Tires Front: Single, highway tread
Rear: Dual, highway tread
255/70R 22.5
Wheels Steel disc type, 8 hole,
7.50 x 22.5 in., offset 6.38 in.

BRAKE SYSTEM

Service Brakes Anti-lock Braking System
Dual line, air-over-hydraulic brake system
Front Internal expanding, two leading shoe,
self-adjusting drum brakes
Drum diameter x lining width x lining
thickness: 15.75 x 4.72 x 0.59 in.
Rear Internal expanding, dual two leading shoe,
self-adjusting drum brakes
Drum diameter x lining width x lining
thickness: 15.75 x 6.10 x 0.59 in.
Air Tanks Supply: 641 in.³
Front service: 549 in.³
Rear service: 641 in.³
Total: 1,831 in.³
Air Dryer Standard
Parking Brake Hand brake lever activating drum at
rear of transmission

EXHAUST BRAKE

Electrically controlled, pneumatically
activated butterfly valve in exhaust pipe

CHASSIS FRAME

Ladder type, channel section side rails

Dimensions (in.) * 9.84 x 3.15 x 0.31
Assembled Width (in.) 33.9
Section Modulus (in.³) ** 26.6
Yield Strength (psi) 51,200
RBM (in.-lb.) 1,362,000

*Height x Flange Width x Thickness **Measured at back-of-cab, specifications
based on complete chassis (both rails)

FUEL TANK

Round fuel tank, mounted to left side
Capacity - 50 gallons

CAB

Forward control, steel construction, tilting
cab. Cab suspension w/ shock absorbers
Air Conditioner Standard
Cab Glass Windshield, tinted laminated, 2,314 in.²
Cruise Control Standard
Door Locks Driver & passenger, electric control
Door Vent Window Driver, ventilating type
Driver's Seat Height & seat back angle adjustable, with
air suspension. Cloth cover, high back type
Standard
Floor Mats Standard
Keyless Entry Standard
Passenger Seat Seat back angle adjustable
Cloth cover, high back type
Seat Belts Driver & passenger, 3-point ELR type
Rearview Mirrors West coast type, 5.4 x 15.5 in.
Steering Column Tilt & telescopic type
Sun Visors Driver & passenger
Windows Driver & passenger, electric control
Windshield Wipers Dual, electric-driven, intermittent & 2 speed

ELECTRICAL EQUIPMENT

Back-up lights
Cigar lighter
Clearance, identification & position lights
Day-time running lights
Halogen headlights, 2 lamps
Interior and map light
License light
Side turn signal lights
Stop/tail lights
Turn signal/hazard lights
Power outlet - 12 volt

INSTRUMENTS

Meters & Gauges

Air pressure gauges
Coolant temperature gauge
Fuel gauge
Speedometer, odometer & trip meter
Tachometer

Warning & Indicator Lights & Buzzers

ABS warning light
Alternator low charge warning light
Automatic Transmission:
- Check warning light
- Range inhibited warning light
- High temperature fluid warning
light & buzzer
Engine glow plug indicator light
Cab lock warning light & buzzer
Engine control system warning light
External air restriction indicator
Exhaust brake indicator light
Hazard warning flasher
High beam indicator light
Low air pressure warning light & buzzer
Low brake fluid level warning light
& buzzer
Low coolant level & overheating
warning light & buzzer
Low oil pressure warning light
Parking brake indicator light
Sedimentor warning light
Service brake warning light & buzzer
Turn signal indicator lights
Warning lights with burnt-out bulb
check function
DPF warning/indicator lights

OTHER OPTIONS

AM/FM stereo radio with CD
Block heater
Center console/ third seat
Rear wheel parking brake
Heated mirrors
Rear traction tires

All illustrations, specifications and descriptions in this specification are based on the
latest product information available at the time of this publication. The right is
reserved to make changes in price, materials, equipment, design, specifications, dia-
grams and models, and to discontinue models of equipment at any time, without
notice and without incurring any obligation whatsoever. For more information on
additional options and accessories, contact NISSAN DIESEL AMERICA, INC.

Manufacturer:
NISSAN DIESEL MOTOR CO., LTD.
Saitama, Japan

Distributor:
NISSAN DIESEL AMERICA, INC.
P.O. Box 152034
Irving, Texas 75015-2034
www.udtrucks.com