

UD2600LP

2007 MODEL YEAR



TRUCKS

Distributed by

Nissan Diesel America, Inc.

WHEELBASES

	G	K
GVWR (lb.)	25,995	25,995
Chassis Weight (lb.)	9,240	9,305
Front (lb.)	5,760	5,795
Rear (lb.)	3,480	3,510
Gross Payload (lb.)*	16,755	16,690
Wheelbase (in.) ** WB	171.3	187.0
Cab-to-Rear Axle (in.) CA	139.1	154.9
Rear Overhang (in.) RO	78.7	82.9
Overall Length (in.) OL	300.4	320.3
Typical Body Lengths (ft.)***	16/18	18/20
Turning Radius (ft.)	24.3+	26.3+

*Gross payload capacity equals GVWR minus chassis weight. Installation of specialized equipment or bodies may require frame reinforcement. **Wheelbase selection should be based on specific weight distribution. ***Typical body lengths assume water level load (no specific consideration for driver, passengers, or fuel) to maximize GVWR. Addition of ancillary equipment such as lift gates and refrigeration units not considered in calculations.

+ Turning radius values are approximate and subject to change.

ENGINE

	MD230* - 24 Valve
	Turbo/Intercooled Diesel
	In-line 6 cylinder, Direct-injection
Horsepower	230 hp @ 2,500 rpm
Torque	506 lb. ft. @ 1,500 rpm
Displacement	469 in. ³ (7.684 L)
Cylinder Liner	Dry, replaceable
Air Compressor	14.1 CFM @ 2,600 engine rpm (nominal)
Fuel System	Electronically controlled common rail system
Air Cleaner	11 in., paper filter type (DONALDSON)
Cold Starting Aid	Automatic electric glow plug
Fan	Viscous type drive

*MD230 (J08E-TE) is a vendor engine manufactured for Nissan Diesel Motor Company.

FRONT AXLE

Rated Axle Capacity	9,480 lb.
Axle Type	"I" Beam
Suspension	Semi-elliptic leaf springs
Shock Absorbers	Telescopic type



*UD2600 shown here with dealer installed optional equipment.

TRANSMISSION

Ratios	STD	OPTION
	Nissan Diesel, MLS63B Manual, 6 forward speeds & 1 reverse synchromesh on 2nd through 6th gears	Allison, 2200RDS Automatic 5 forward speeds & 1 reverse
1st	6.72	3.51
2nd	4.03	1.90
3rd	2.30	1.44
4th	1.44	1.00
5th	1.00	0.74
6th	0.74	—
Rev.	6.12	5.09
R/A Ratio	4.88	4.88
Engine rpm @ 65 mph		
w/ 255/70R22.5	2,185	2,194

*Approximate engine rpm only. Allison will provide a performance scan by application on request.

CLUTCH

Hydraulic clutch with air assist
13.8 in. cerametallic friction material
Standard clutch wear indicator

STEERING

Integral power steering, gear driven pump
Steering Column Tilt & telescopic type

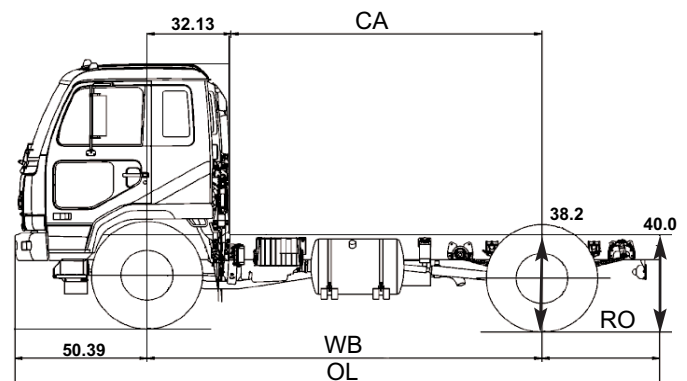
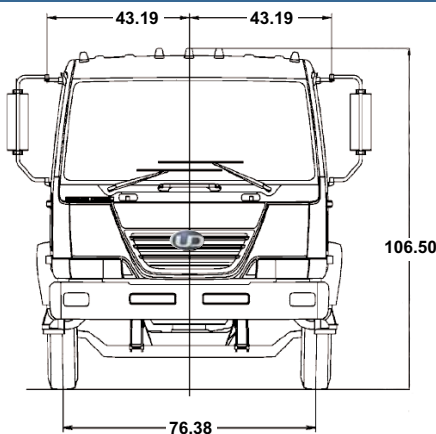

UD2600LP

2007 MODEL YEAR



TRUCKS

Distributed by
Nissan Diesel America, Inc.

REAR AXLE

Rated Axle Capacity	18,080 lb.
Axle Type	Full-floating banjo housing
Suspension	Semi-elliptic leaf springs with auxiliary springs

WHEELS & TIRES

Tires	Front: Single, highway tread Rear: Dual, traction type 255/70R 22.5
Wheels	Steel disc type, 8 hole, 7.50 x 22.5 in., offset 6.38 in.

BRAKE SYSTEM

Service Brakes	Anti-lock Braking System Dual line, air-over-hydraulic brake system
Front	Internal expanding, two leading shoe, self-adjusting drum brakes Drum diameter x lining width x lining thickness: 15.75 x 4.72 x 0.59 in.
Rear	Internal expanding, dual two leading shoe, self-adjusting drum brakes Drum diameter x lining width x lining thickness: 15.75 x 6.10 x 0.59 in.
Air Tanks	Supply: 641 in. ³ Front service: 549 in. ³ Rear service: 641 in. ³ Total: 1,831 in. ³
Air Dryer	Standard
Parking Brake	Hand brake lever activating drum at rear of transmission

EXHAUST BRAKE

Electrically controlled, pneumatically activated butterfly valve in exhaust pipe

CHASSIS FRAME

Ladder type, channel section side rails

Dimensions (in.) *	9.84 x 3.15 x 0.31
Assembled Width (in.)	33.9
Section Modulus (in. ³) **	26.6
Yield Strength (psi)	42,600
RBM (in.-lb.)	1,133,000

*Height x Flange Width x Thickness **Measured at back-of-cab, specifications based on complete chassis (both rails)

FUEL TANK

Round fuel tank, mounted to left side
Capacity - 50 gallons

CAB

Air Conditioner	Standard
Cab Glass	Windshield, tinted laminated, 2,314 in. ²
Cruise Control	Standard
Door Locks	Driver & passenger, electric control
Door Vent Window	Driver, ventilating type
Driver's Seat	Height & seat back angle adjustable, with air suspension. Cloth cover, high back type
Keyless Entry	Standard
Passenger Seat	Seat back angle adjustable Cloth cover, high back type
Seat Belts	Driver & passenger, 3-point ELR type
Rearview Mirrors	West coast type, 5.4 x 15.5 in.
Steering Column	Tilt & telescopic type
Sun Visors	Driver & passenger
Windows	Driver & passenger, electric control
Windshield Wipers	Dual, electric-driven, intermittent & 2 speed

ELECTRICAL EQUIPMENT

Back-up lights
Cigar lighter
Clearance, identification & position lights
Day-time running lights
Halogen headlights, 2 lamps
Interior and map light
License light
Side turn signal lights
Stop/tail lights
Turn signal/hazard lights

INSTRUMENTS

Meters & Gauges

Air pressure gauges
Coolant temperature gauge
Fuel gauge
Speedometer, odometer & trip meter
Tachometer

Warning & Indicator
Lights & Buzzers

ABS warning light
Alternator low charge warning light
Automatic Transmission:
- Check warning light
- Range inhibited warning light
- High temperature fluid warning
light & buzzer
Engine glow plug indicator light
Cab lock warning light & buzzer
Engine control system warning light
External air restriction indicator
Exhaust brake indicator light
Hazard warning flasher
High beam indicator light
Low air pressure warning light & buzzer
Low brake fluid level warning light
& buzzer
Low coolant level & overheating
warning light & buzzer
Low oil pressure warning light
Parking brake indicator light
Sedimentor warning light
Service brake warning light & buzzer
Turn signal indicator lights
Warning lights with burnt-out bulb
check function

OTHER OPTIONS

AM/FM stereo radio with CD
Block heater
Center console/ third seat
Rear wheel parking brake

All illustrations, specifications and descriptions in this specification are based on the latest product information available at the time of this publication. The right is reserved to make changes in price, materials, equipment, design, specifications, diagrams and models, and to discontinue models of equipment at any time, without notice and without incurring any obligation whatsoever. For more information on additional options and accessories, contact NISSAN DIESEL AMERICA, INC.

Manufacturer:
NISSAN DIESEL MOTOR CO., LTD.
Saitama, Japan

Distributor:
NISSAN DIESEL AMERICA, INC.
P.O. Box 152034
Irving, Texas 75015-2034
www.udtrucks.com