

# UD1300

2006 MODEL YEAR



# TRUCKS

Distributed by

**Nissan Diesel America, Inc.**

WHEELBASES	A	C	E
GVWR (lb.)	13,000	13,000	13,000
Chassis Weight (lb.)	5,390	5,500	5,620
Front (lb.)	3,725	3,835	3,925
Rear (lb.)	1,665	1,665	1,695
Gross Payload (lb.)*	7,610	7,500	7,380
Wheelbase (in.)** WB	108.9	131.9	149.4
Cab-to-Rear Axle (in.) CA	83.4	106.4	123.9
Rear Overhang (in.) RO	49.6	49.6	49.6
Overall Length (in.) OL	203.2	226.2	243.7
Typical Body Lengths (ft.)***	10/12	14/16	16/18
Turning Radius (ft.)	17.4	20.7	23.0

\*Gross payload capacity equals GVWR minus chassis weight. Installation of specialized equipment or bodies may require frame reinforcement. \*\*Wheelbase selection should be based on specific weight distribution. \*\*\*Typical body lengths assume water level load (no specific consideration for driver, passengers, or fuel) to maximize GVWR. Addition of ancillary equipment such as lift gates and refrigeration units not considered in calculations.

## ENGINE

	MD-175* 16 valve Turbo/Intercooled Diesel In-line 4 cylinder, Direct-injection
Horsepower	175 hp @ 2,700 rpm (automatic transmission)
Torque	347 lb. ft. @ 1,600 rpm (automatic transmission)
Displacement	289 in. <sup>3</sup> (4.728 L)
Cylinder Liner	Dry, replaceable
Fuel System	Electronically controlled common rail system
Air Cleaner	11.0 in., dry type
Cold Starting Aid	Automatic electric glow plug
Fan	Viscous type drive

\*MD-175 (J05D-TA) is a vendor engine manufactured for Nissan Diesel Motor Company

## FRONT AXLE

GAWR	4,670 lb.
Rated Axle Capacity	6,170 lb.
Axle Type	"I" Beam
Suspension	Semi-elliptic leaf springs
Shock Absorbers	Double acting, telescopic type



\*UD1300 shown here with dealer installed optional equipment.

## TRANSMISSION

Aisin A45043L  
Automatic Full electronic control  
4 speed overdrive with lockup & park lock

## Ratios

1st	3.02
2nd	1.55
3rd	1.00
4th	0.70
Rev.	2.68
R/A Ratio	5.29
Engine rpm @ 65 mph	2,750

## STEERING

Steering Column      Integral power steering  
Tilt & telescopic type

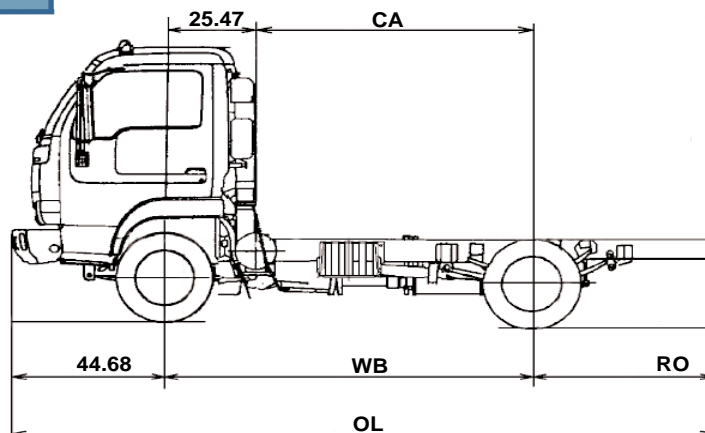
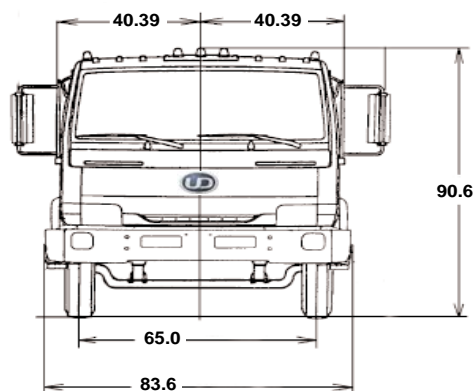

# UD1300

2006 MODEL YEAR



# TRUCKS

Distributed by  
**Nissan Diesel America, Inc.**

## REAR AXLE

GAWR	8,600 lb.
Rated Axle Capacity	11,500 lb.
Axle Type	Full-floating banjo housing
Suspension	Semi-elliptic leaf springs with auxiliary springs
Shock Absorbers	Double acting, telescopic type

## WHEELS & TIRES

Tires	Front: Single, highway tread & tires Rear: Dual, traction type 215/85R16 - 8PR (tubeless radial)
Wheels	Steel disc type, 5 hole, 6 x 16 in., offset 5.0 in.

## BRAKE SYSTEM

Service Brakes	Anti-lock Braking System Dual line, hydraulic brake system with vacuum assist
Front	Ventilated disc brakes
Rear	Internal expanding, dual two leading shoe, self-adjusting drum brakes
Parking Brake	Hand brake lever activating drum at rear of transmission

## EXHAUST BRAKE

Electrically controlled, vacuum activated  
butterfly valve in exhaust pipe

## CHASSIS FRAME

Ladder type, channel section side rails

Dimensions (in.) *	7.09 x 2.36 x 0.18
Assembled Width (in.)	29.5
Section Modulus (in. <sup>3</sup> ) **	6.29 (per rail)
Yield Strength (psi)	44,000
RBM (in.-lb.)**	554,000

Rear Inner Reinforcement STD on A&E Wheelbase

\*Height x Flange Width x Thickness \*\*Measured at back-of-cab, specifications  
based on complete chassis (both rails)

## FUEL TANK

Round fuel tank, mounted to right side  
Capacity - 33 gallons

## CAB

Air Conditioner	Forward control, steel welded construction, tilting cab with cab suspension
Assist Handles	Standard
Cab Glass	Two, driver & passenger
Center Console	Windshield, tinted laminated glass - 1900 in. <sup>2</sup> Standard
Center Seat	Folding with center console
Door Locks	Driver & passenger, electric control
Driver's Seat	Fore/aft and seat back angle adjustable cloth cover with headrest
Keyless Entry	Standard
Passenger Seat	Fixed with headrest
Seat Belts	Driver & passenger, 3-point ELR type, center seat w/2-point lap belt
Rearview Mirrors	West coast type, 5.4 x 15.5 in.
Steering Column	Tilt & telescopic type
Sun Visors	Driver & passenger
Windows	Driver & passenger, electric control
Windshield Wipers	Dual, electric-driven, intermittent & 2 speed

## ELECTRICAL

Back-up lights  
Cigar lighter  
Clearance, identification & side  
marker lights  
Day-time running lights  
Halogen headlights, 2 lamps  
Interior light  
License light  
Side turn signal lights  
Stop/tail lights  
Turn signal/hazard lights

## INSTRUMENTS

Meters & Gauges	Coolant temperature gauge Fuel gauge Speedometer, odometer & trip meter Tachometer
Warning & Indicator Lights & Buzzer	ABS warning light Alternator low charge warning light Automatic transmission: - Check warning light - High temperature fluid warning light - Overdrive cancel indicator light Brake low vacuum warning light Engine control system warning light Engine glow plug indicator light Exhaust brake indicator light Hazard warning flasher High beam indicator light Low oil pressure warning light Low brake fluid level warning light Low coolant level light & buzzer Parking brake indicator light Sedimentor warning light Turn signal indicator lights Warning lights with burn-out bulb check function

## OTHER OPTIONS

AM/FM stereo radio with CD  
Block heater

## NOT AVAILABLE FOR SALE in California, Massachusetts Maine, New York and Vermont.

All illustrations, specifications and descriptions in this specification are based on the  
latest product information available at the time of this publication. The right is  
reserved to make changes in price, materials, equipment, design, specifications, dia-  
grams and models, and to discontinue models of equipment at any time, without  
notice and without incurring any obligation whatsoever. For more information on  
additional options and accessories, contact NISSAN DIESEL AMERICA, INC.

Manufacturer:  
NISSAN DIESEL MOTOR CO., LTD.  
Saitama, Japan

Distributor:  
NISSAN DIESEL AMERICA, INC.  
P.O. Box 152034  
Irving, Texas 75015-2034  
www.udtrucks.com